

Four-pipe Compact Four-way Cassette Fan Coil Unit

1. Introduction	2
2. Nomenclature	3
3. Product Schedule	4
4. External Appearance	5
5. Features	6
6. Specifications.....	7
7. Dimension and Sound Levels	8
8. Main PCB ports	12
9. Wiring Diagrams	14
10. Capacity Tables	16
11. Exploded View	20
12. Installation	21

1. Introduction

Fan coil unit is a kind of compound device which assemble fan and surface-type coil heating-exchanger together. Fan coil has horizontal type, vertical type, etc. A cooling (heating) supply system usually consists of fan coil terminals and chilled water system (heated water system).

Midea® commercial AC fan coil is designed and manufactured on the base of advanced technology, and utilize qualified galvanized iron as material. Due to its supper-thin design, it has such advantages: beautiful outlook, space saving, easy installation, etc. And the most obvious advantage is that it can decrease the outlet air Temp-difference as low as possible to make room more comfortable, as well as don't decrease cooling capacity output. For the large air flow volume design, it can increase room ventilation frequency, supply more flesh air, and balance room temperature distribution. Benefiting from adoption of advanced material and technology, it can effectively decrease the running noise and keep running smoothly. With the advantages above, it can be widely applied in market, hospital, office building, hotel airport, etc..

2. Nomenclature

M K D - 500 S

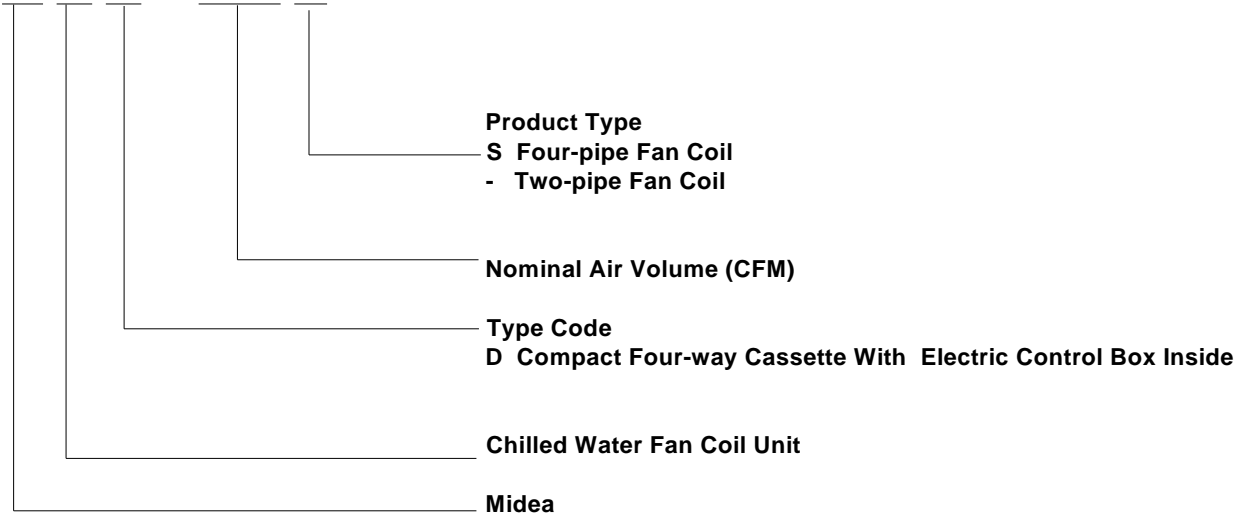

3. Product Schedule

Type	Model	Air volume (m ³ /h)	Power supply (V-ph-Hz)	Auxiliary Electrical Heater
4-pipe	MKD-300S	510	220~240-1-50	Without
	MKD-400S	680	220~240-1-50	Without
	MKD-500S	850	220~240-1-50	Without

4. External Appearance



5. Features

- Capacity range:300~500CFM
- Round blow air supply enables uniform air flow distribution



- Compact design, simple installation and easy maintenance

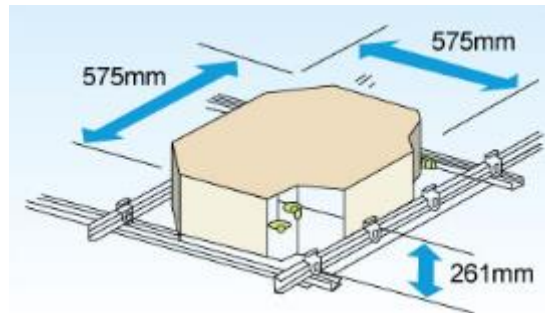

- Built-in drain water pump with 500mm pumping head

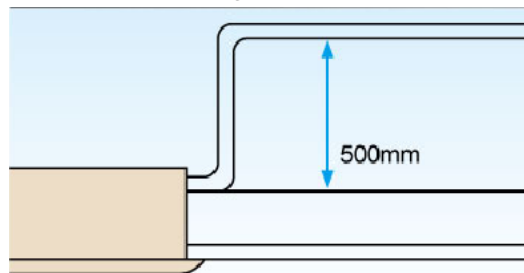

- High comfortable, cold and hot water can supply simultaneously
- Cooling and heating model can exchange conveniently



- High capacity of cooling and heating performance, high efficiency and energy-saving
- Four-speed motor with one reserved more choice

6. Specifications

Model MKD-			300S	400S	500S
Air Volume	High	m ³ /h	510	680	850
		CFM	300	400	500
	Med	m ³ /h	440	580	730
		CFM	260	340	430
	Low	m ³ /h	360	480	600
		CFM	210	280	350
Cooling Capacity		W	2,500	2,900	3,500
Heating Capacity		W	3,700	4,600	5,100
Power Input		W	50	70	95
Current input		A	0.23	0.32	0.43
Noise(Hi/Med/Lo)		dB(A)	36/33/28	42/39/32	45/42/34
Water Flow	Cooling	l/min	7.2	8.4	10
	Heating	l/min	5.3	6.6	7.3
Water Pressure Drop	Cooling	kPa	22	16	24
	Heating	kPa	17	23	27
Fan Motor	Type		Low noise 4-speed fan motor		
	Model		YDK15-6P	YDK37-4P	YDK37-4P
	Capacitor	uF	1.5	2	2.5
	Quantity		1		
Fan	Type		Centrifugal, forward-curved Blades		
	Quantity		1		
Coil	Row		2		
	Tube pitch(a)x row pitch(b)	mm	21x13.37		
	Fin spacing	mm	1.3		
	Fin type		Hydrophilic aluminium		
	Tube outside dia.	mm	Φ7		
	Coil length x height		1315x210		
	Number of circuits		3 for cold water 3 for hot water	4 for cold water 3 for hot water	4 for cold water 3 for hot water
	Max. Working Pressure	MPa	1.6		
Panel	Net Dimension (WxHxD)	mm	647x50x647		
	Net Weight	kg	2.6		
	Packing Size (WxHxD)	mm	715x123x715		
	Gross Weight	kg	4.7		
Indoor Unit	Net Dimension (WxHxD)	mm	575x261x575		
	Net Weight	kg	17.5		
	Packing Size (WxHxD)	mm	670x290x670		
	Gross Weight	kg	21.5		
Pipe Connection	Water-inlet pipe	Inch	Cold water: G3/4" Hot water: G1/2"		
	Water-outlet pipe	Inch	Cold water: G3/4" Hot water: G1/2"		
	Drain pipe	mm	ODΦ25		
Controller			R51/E (standard)		

Note: 1. The data is the performance in high speed.

2. Cooling Conditions: Entering Water 7°C, Temperature Rise 5°C, Entering Air Temperature 27°C DB, 19°CWB.

Heating Conditions: Entering Water 70°C, Entering/leaving temperature difference is 10°C, enter air temperature 20°C

3. Noise level is tested in semi-anechoic room

7. Dimension and Sound Levels

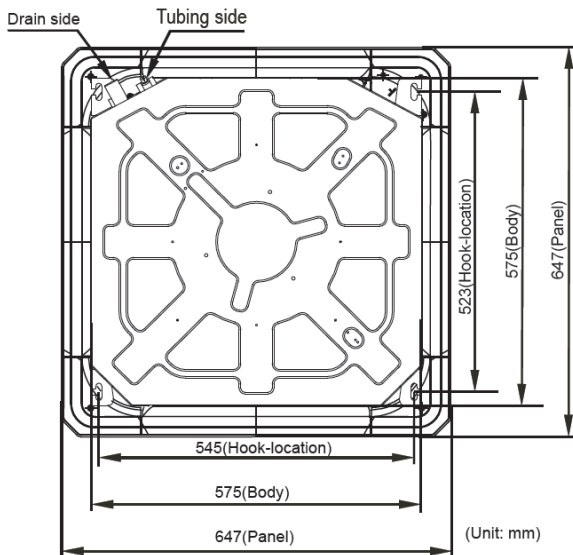

Four-Pipe

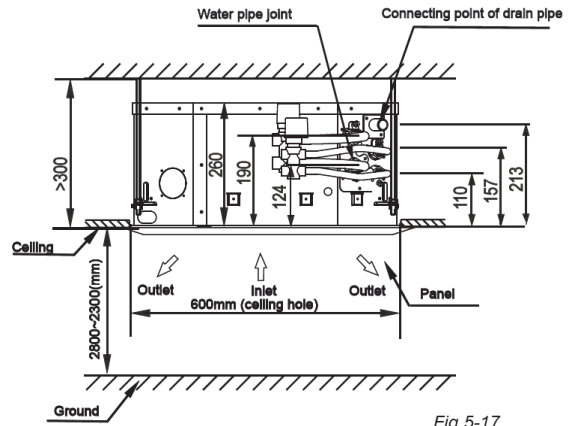
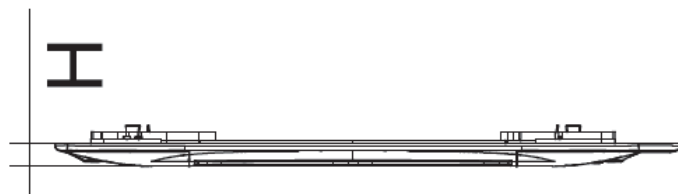
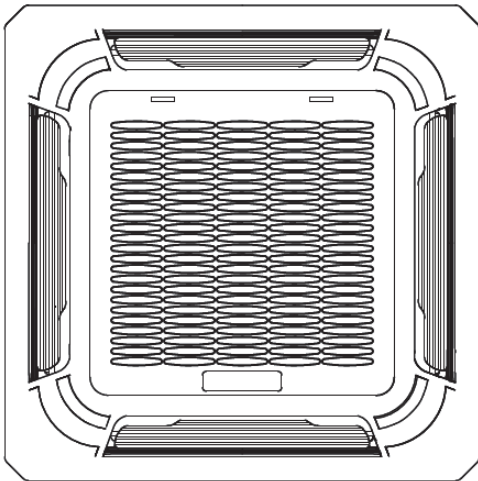
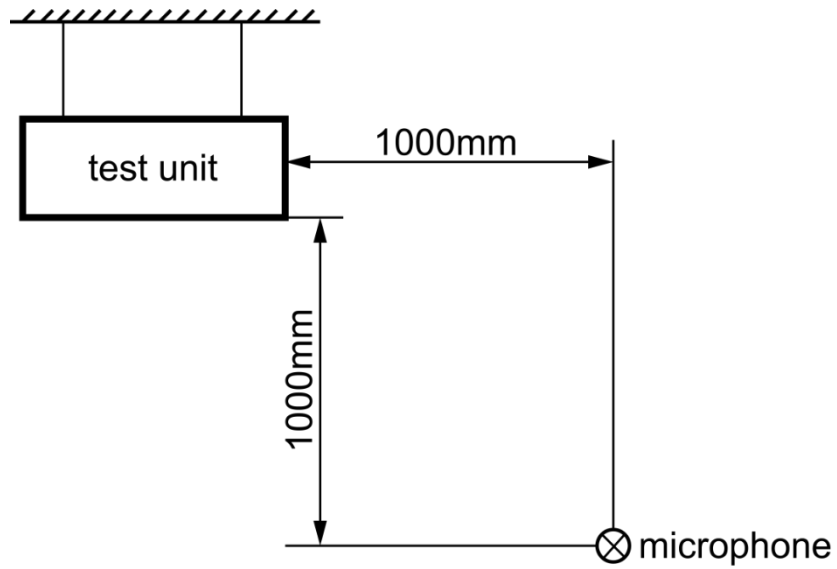

Fig.5-17



H(mm)	50
-------	----



Models	H	M	L
MKD-300S	36	33	28
MKD-400S	42	39	32
MKD-500S	45	42	34

MKD-300S

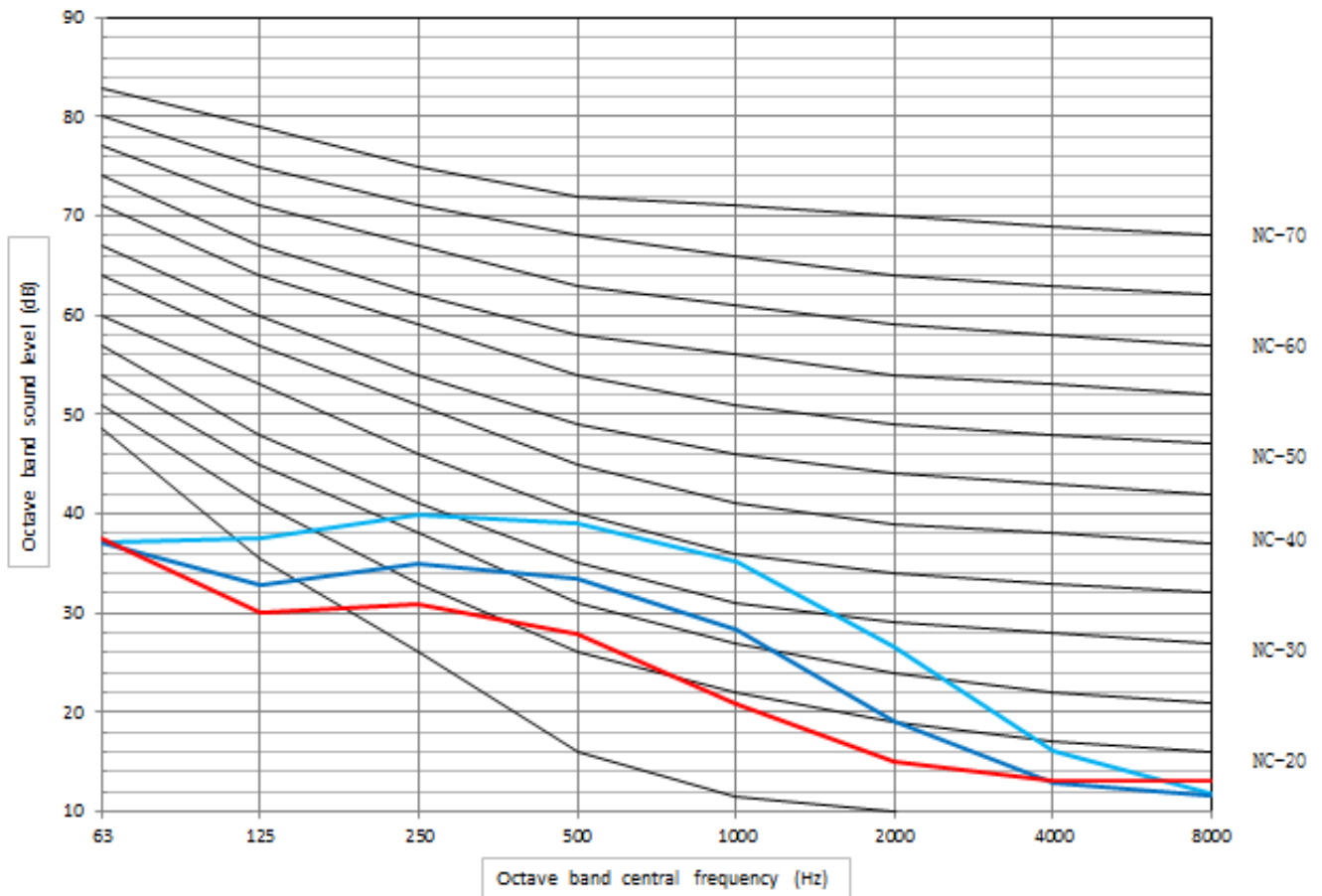

MKD-400S

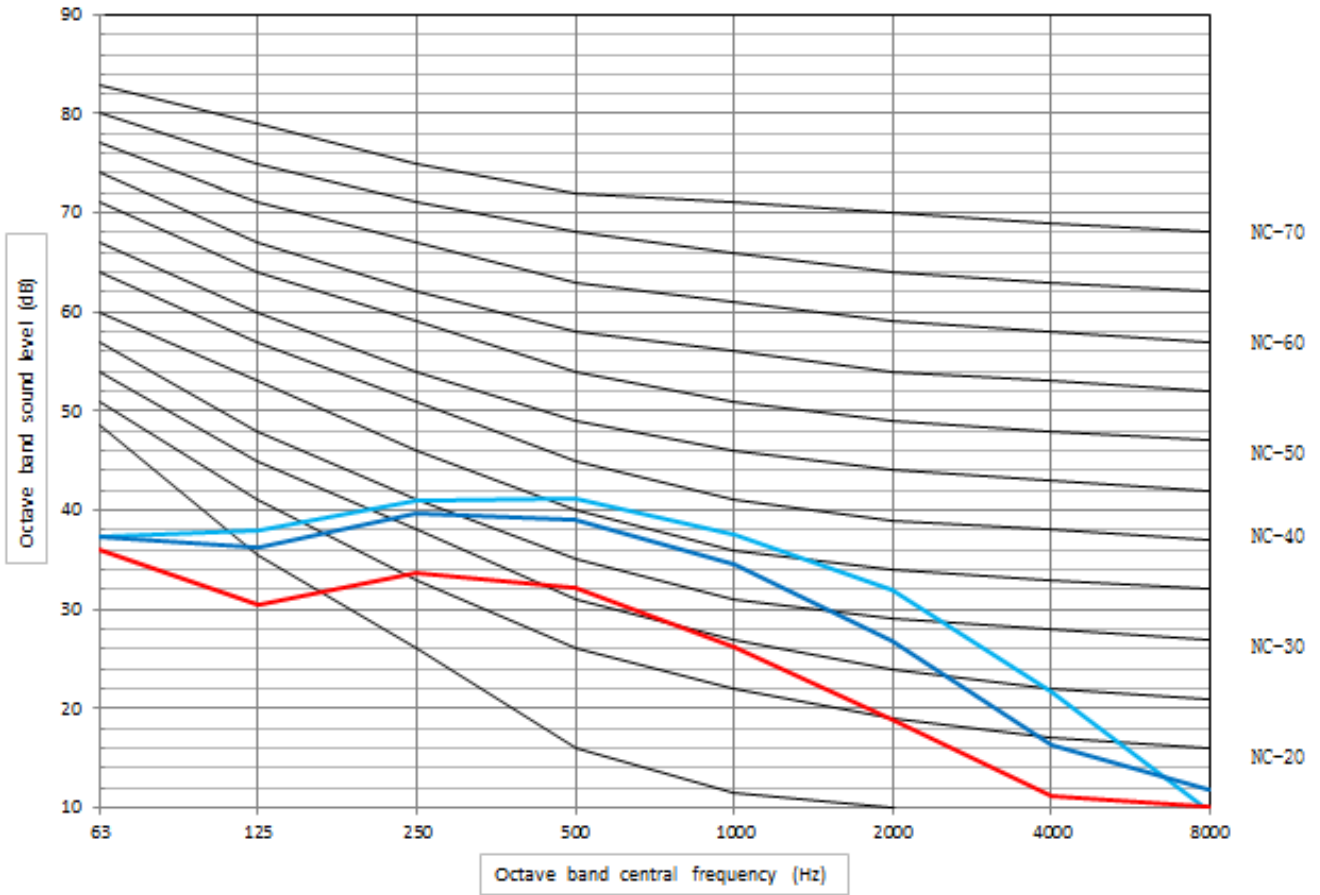

MKD-500S

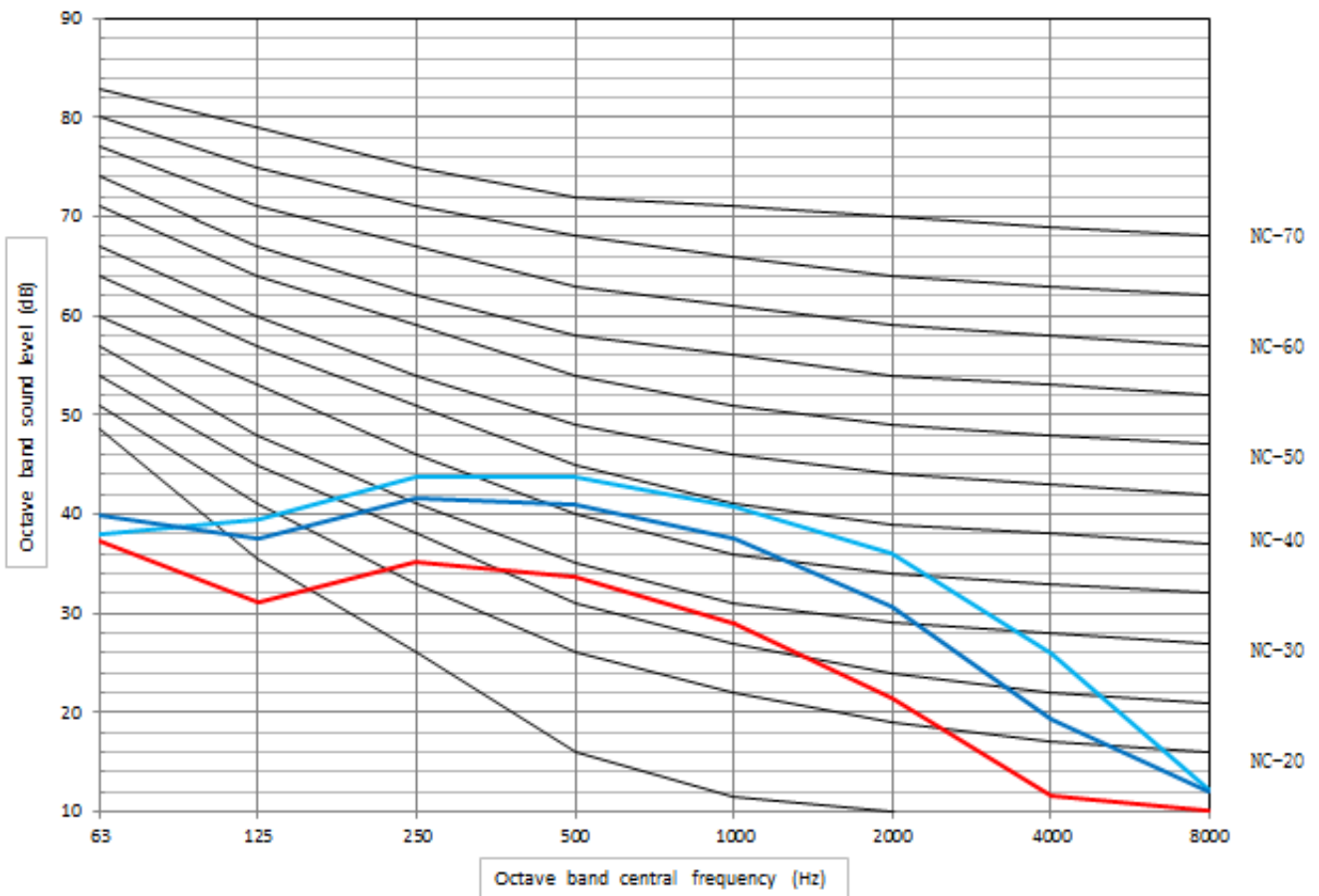

8. Main PCB ports

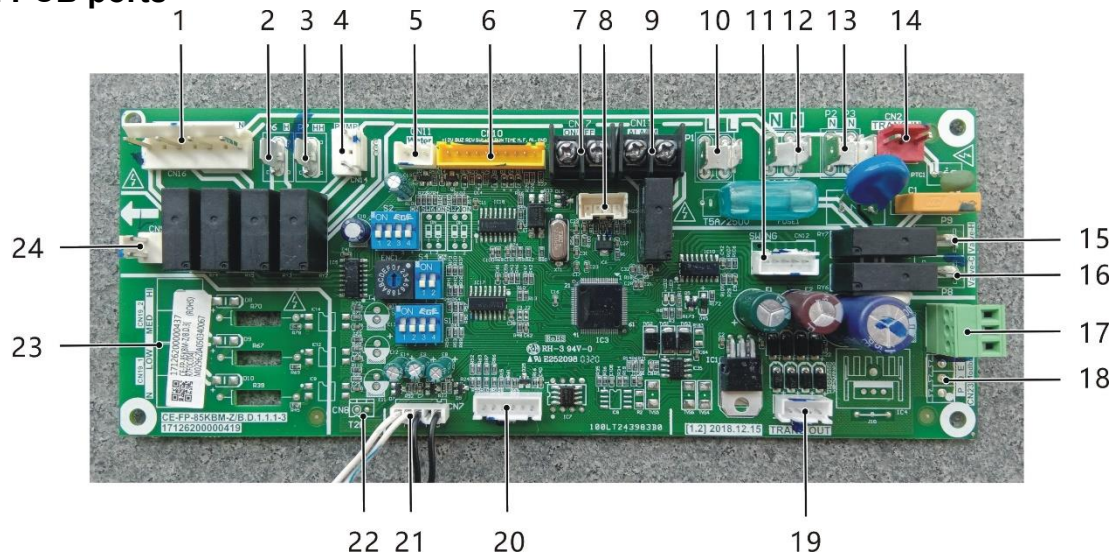

Main PCB port description:

No.	Bit No.	Description	Remarks
1	CN16	L: Low fan speed output port for AC fan	Standard
		M: Medium fan speed output port for AC fan	
		H: High fan speed output port for AC fan	
		N: Null line output port for AC fan	
2	P6	H: High fan speed output port for AC fan	Standard
3	P7	HH: Super-high wind profile reserved port for AC fan (suspended)	Standard
4	CN14	PUMP: Water pump output port	Standard
5	CN11	WATER: Water level switch port	Standard
6	CN10	:Display panel docking port (ten cores)	Standard
7	CN17	ON/OFF: Remote on/off port	Standard
8	CN25	Main control program burn port	Standard
9	CN13	ALARM: Fault alarm output	Standard
10	P1	L: Power live line input	Standard
11	CN12	SWING: Swing motor port	Standard
12	P4	N: Power null line input	Standard
	P5	N: Power null line input	Standard
13	P2	N: Cooling and heating 2-way/3-way valve null line	Standard
	P3	N: Cooling and heating 2-way/3-way valve null line	Standard
14	CN2	TRANS IN: Linear transformer primary	Standard
15	P9	Valve-H: Heating 2-way/3-way valve live line	Standard (four pipe only)
16	P8	Valve-C: Cooling 2-way/3-way valve live line	Standard
17	CN18	XYE: Centralized control communication port	Standard
18	CN23	PQE: Modbus communication port	Customized
19	CN3	TRANS OUT: Linear transformer secondary	Standard
20	CN22	E - side program burning port	Standard
21	CN7	T2C: Refrigerating pipe temperature sensor port	Standard
		T1: Room temperature sensor port	Standard

22	CN8	T2H: Heating pipe temperature sensor port	Standard (four pipe only)
23	CN19_1	N: Mechanical three-speed wire controller with null line	Customized
		LOW: Mechanical three-speed wire controller with low speed	Customized
	CN19_2	MED: Mechanical three-speed wire controller with medium speed	Customized
		HI: Mechanical three-gear wire controller with high speed	Customized
24	CN9	HEAT: Control port for auxiliary electric heating relay	Customized

NOTE:

1. ALARM: Error codes or protections occurred, a closed signal output.
2. ON/OFF: Short circuit, forced off; otherwise, all the controllers available.

WIRING DIAGRAM	
CODE	PART NAME
CAP1	INDOOR FAN CAPACITOR
CN1-23,P1-9	P.C BOARD SOCKETS
AC FAN	INDOOR FAN MOTOR
K3	WATER LEVEL SWITCH
M	SWING MOTOR
P	PUMP
T1	ROOM TEMPERATURE
T2C/T2H	PIPE TEMPERATURE
XP1-7	CONNECTORS
XS1-7	CONNECTORS
XT1-2	3-WAY TERMINAL
TRANS	POWER TRANSFORMER

S1		2 pipe	S2-1/2		Temp.compensation value is 0 under cool mode(default)
		4 pipe(default)			Temp.compensation value is 1 under cool mode
		Without enforcement to turn wind(default)			Temp.compensation value is 2 under cool mode
		With enforcement to turn wind			Temp.compensation value is 3 under cool mode
S1		Normal anti-cold wind(default)	S2		Temp.compensation value is 3 under heat mode(default)
		High temperature anti-cold wind			Temp.compensation value is 1 under heat mode
		turn on E-heater and heating valve. (default setting)			Temp.compensation value is 6 under heat mode
		turn on E-heater, turn off heating valve			Temp.compensation value is 8 under heat mode

	0
	1

ENC1 & S4	SWTCH FOR ADDRESS SETTING		Address 0-15
	'0-F' of the ENC1 and 'ON/OFF' of the S4, the different position represents a different address. Is be combined 64 address(0-63)		Address 16-31
			Address 32-47
			Address 48-63

10. Capacity Tables

Cooling Capacity:

Remark: **EWT:** Enter Water Temp. (°C); **Δt:** Temperature Difference (°C);
DB: Dry Bulb Temp. (°C); **WB:** Wet Bulb Temp. (°C);
TC: Total Cooling Capacity (kW); **SC:** Sensible Cooling Capacity (kW);
WF: Water Flow (m³/h); **WPD:** Water Pressure Drop (kPa)

MKD-300S																					
EWT	Δt	Air inlet condition																			
		DB:26.7 WB:19.4				DB:27 WB:18				DB:27 WB:19				DB:27 WB:20				DB:29 WB:21			
		TC	SC	WF	WPD	TC	SC	WF	WPD	TC	SC	WF	WPD	TC	SC	WF	WPD	TC	SC	WF	WPD
5	3	3.19	1.92	0.91	99.2	2.92	2.11	0.84	83.5	3.12	2	0.89	95.2	3.3	1.92	0.95	106.5	3.48	1.83	1	118.7
	4	3.06	1.86	0.66	51.6	2.81	2.05	0.6	43.6	3.01	1.94	0.65	49.9	3.19	1.86	0.69	55.9	3.35	1.77	0.72	61.6
	5	2.93	1.8	0.5	30.2	2.68	2	0.46	25.3	2.87	1.88	0.49	29.0	3.06	1.79	0.53	33.0	3.22	2.78	0.55	36.5
	6	2.8	1.75	0.4	19.2	2.55	1.93	0.37	15.9	2.75	1.82	0.39	18.4	2.94	1.72	0.42	21.1	3.08	1.64	0.44	23.2
	7	2.66	1.66	0.33	12.7	2.41	1.88	0.3	10.4	2.6	1.76	0.32	12.2	2.79	1.66	0.34	14.0	2.95	1.57	0.36	15.6
6	3	3.01	1.84	0.86	88.3	2.74	2.03	0.78	73.3	2.94	1.92	0.84	84.3	3.13	1.83	0.9	95.7	3.31	1.75	0.95	107.0
	4	2.89	1.78	0.62	45.8	2.62	1.97	0.56	37.6	2.82	1.86	0.61	43.7	3.01	1.77	0.65	49.7	3.17	1.69	0.68	55.4
	5	2.75	1.71	0.47	26.5	2.5	1.91	0.43	21.9	2.69	1.8	0.46	25.5	2.87	1.7	0.49	29.0	3.05	1.62	0.52	32.7
	6	2.62	1.66	0.37	16.7	2.37	1.85	0.34	13.7	2.55	1.74	0.37	16.0	2.75	1.63	0.39	18.4	2.9	1.55	0.42	20.5
	7	2.48	1.59	0.3	11.0	2.22	1.8	0.27	8.8	2.42	1.69	0.3	10.5	2.59	1.58	0.32	12.1	2.77	1.49	0.34	13.8
7	3	2.81	1.75	0.8	77.0	2.55	1.95	0.73	63.4	2.75	1.84	0.79	73.7	2.95	1.75	0.84	84.9	3.11	1.66	0.89	94.8
	4	2.69	1.69	0.58	39.8	2.41	1.91	0.52	32.0	2.62	1.78	0.56	37.7	2.81	1.69	0.6	43.6	2.99	1.61	0.64	49.2
	5	2.55	1.63	0.44	23.0	2.29	1.85	0.39	18.5	2.5	1.72	0.43	22.0	2.68	1.62	0.46	25.3	2.85	1.54	0.49	28.5
	6	2.42	1.58	0.35	14.3	2.16	1.79	0.31	11.4	2.38	1.66	0.34	13.8	2.56	1.55	0.37	16.0	2.72	1.47	0.39	18.0
	7	2.29	1.51	0.28	9.4	2.01	1.72	0.25	7.3	2.22	1.61	0.27	8.8	2.41	1.5	0.3	10.4	2.57	1.41	0.32	11.9
8	3	2.62	1.68	0.75	66.9	2.33	1.88	0.67	53.3	2.55	1.76	0.73	63.8	2.75	1.66	0.79	73.9	2.93	1.57	0.84	83.7
	4	2.5	1.62	0.54	34.4	2.22	1.82	0.48	27.1	2.42	1.72	0.52	32.3	2.62	1.61	0.56	37.6	2.78	1.52	0.6	42.7
	5	2.37	1.55	0.41	19.8	2.08	1.77	0.36	15.3	2.3	1.65	0.4	18.7	2.5	1.55	0.43	21.9	2.67	1.46	0.46	25.0
	6	2.22	1.5	0.32	12.0	1.95	1.72	0.28	9.3	2.18	1.59	0.31	11.6	2.37	1.48	0.34	13.7	2.53	1.39	0.36	15.7
	7	2.09	1.44	0.26	7.8	1.81	1.65	0.22	5.9	2.02	1.53	0.25	7.4	2.22	1.42	0.27	8.8	2.37	1.33	0.29	10.1
9	3	2.43	1.6	0.7	57.8	2.14	1.81	0.61	44.8	2.36	1.68	0.68	54.6	2.56	1.58	0.74	64.3	2.73	1.49	0.78	72.9
	4	2.29	1.54	0.49	29.0	2.01	1.76	0.43	22.3	2.23	1.63	0.48	27.3	2.42	1.53	0.52	32.1	2.59	1.44	0.56	36.9
	5	2.17	1.48	0.37	16.6	1.86	1.72	0.32	12.2	2.1	1.58	0.36	15.6	2.29	1.47	0.39	18.5	2.46	1.37	0.42	21.4
	6	2.03	1.42	0.29	10.1	1.72	1.66	0.25	7.2	1.96	1.53	0.28	9.4	2.16	1.4	0.31	11.5	2.33	1.31	0.33	13.3
	7	1.88	1.36	0.23	6.3	1.61	1.61	0.2	4.6	1.81	1.46	0.22	5.9	2.01	1.36	0.25	7.2	2.17	1.25	0.27	8.5
10	3	2.23	1.52	0.64	48.6	1.92	1.74	0.55	36.0	2.14	1.62	0.61	44.8	2.36	1.51	0.68	54.3	2.54	1.41	0.73	63.1
	4	2.09	1.46	0.45	24.1	1.77	1.71	0.38	17.3	2.02	1.57	0.43	22.5	2.23	1.45	0.48	27.3	2.39	1.36	0.51	31.5
	5	1.96	1.41	0.34	13.5	1.66	1.66	0.29	9.7	1.87	1.52	0.32	12.3	2.09	1.4	0.36	15.3	2.27	1.3	0.39	18.1
	6	1.82	1.35	0.26	8.1	1.58	1.58	0.23	6.1	1.74	1.46	0.25	7.4	1.95	1.32	0.28	9.3	2.12	1.23	0.3	11.0
	7	1.66	1.3	0.2	5.0	1.48	1.48	0.18	4.0	1.58	1.4	0.19	4.5	1.79	1.28	0.22	5.7	1.98	1.17	0.24	7.0
11	3	2.01	1.45	0.58	39.6	1.71	1.71	0.49	28.5	1.94	1.54	0.56	36.8	2.14	1.44	0.61	44.9	2.33	1.34	0.67	53.3
	4	1.89	1.4	0.41	19.6	1.62	1.62	0.35	14.5	1.81	1.49	0.39	18.0	2.02	1.37	0.43	22.4	2.2	1.28	0.47	26.7
	5	1.74	1.35	0.3	10.7	1.54	1.54	0.27	8.4	1.66	1.45	0.29	9.7	1.88	1.32	0.32	12.4	2.06	1.22	0.35	14.9
	6	1.59	1.29	0.23	6.2	1.45	1.45	0.21	5.1	1.53	1.39	0.22	5.7	1.73	1.27	0.25	7.3	1.91	1.16	0.27	8.9
	7	1.41	1.24	0.17	3.6	1.36	1.36	0.17	3.3	1.36	1.36	0.17	3.3	1.57	1.21	0.19	4.4	1.76	1.09	0.22	5.6
12	3	1.8	1.38	0.52	31.7	1.58	1.58	0.45	24.4	1.71	1.49	0.49	28.7	1.94	1.36	0.56	36.8	2.12	1.27	0.61	44.0
	4	1.67	1.33	0.36	15.3	1.5	1.5	0.32	12.5	1.58	1.44	0.34	13.8	1.8	1.31	0.39	17.9	1.99	1.21	0.43	21.9
	5	1.52	1.29	0.26	8.2	1.44	1.44	0.25	7.3	1.44	1.39	0.25	7.3	1.66	1.26	0.29	9.7	1.85	1.15	0.32	12.1
	6	1.35	1.24	0.19	4.5	1.34	1.34	0.19	4.4	1.34	1.31	0.19	4.4	1.51	1.21	0.22	5.6	1.7	1.09	0.24	7.0
	7	1.2	1.2	0.15	2.6	1.24	1.24	0.15	2.8	1.23	1.23	0.15	2.7	1.32	1.15	0.16	3.1	1.54	1.02	0.19	4.3
13	3	1.57	1.32	0.45	24.2	1.46	1.46	0.42	20.8	1.48	1.43	0.43	21.5	1.71	1.3	0.49	28.6	1.91	1.19	0.55	35.7
	4	1.44	1.27	0.31	11.4	1.39	1.39	0.3	10.6	1.39	1.36	0.3	10.6	1.57	1.26	0.34	13.6	1.77	1.14	0.38	17.3
	5	1.28	1.26	0.22	5.8	1.3	1.3	0.22	5.9	1.3	1.3	0.22	5.9	1.44	1.2	0.25	7.3	1.63	1.08	0.28	9.4
	6	1.17	1.17	0.17	3.3	1.21	1.21	0.17	3.6	1.21	1.21	0.17	3.6	1.27	1.16	0.18	3.9	1.48	1.02	0.21	5.3
	7	1.07	1.07	0.13	2.1	1.11	1.11	0.14	2.2	1.11	1.11	0.14	2.2	1.11	1.09	0.14	2.2	1.29	0.97	0.16	3.0

MKD-400S																					
EWT	Δt	Air inlet condition																			
		DB:26.7 WB:19.4				DB:27 WB:18				DB:27 WB:19				DB:27 WB:20				DB:29 WB:21			
		TC	SC	WF	WPD	TC	SC	WF	WPD	TC	SC	WF	WPD	TC	SC	WF	WPD	TC	SC	WF	WPD
5	3	3.7	2.23	1.06	72.2	3.39	2.45	0.97	60.7	3.62	2.32	1.04	69.2	3.83	2.22	1.1	77.5	4.04	2.12	1.16	86.4
	4	3.55	2.16	0.76	37.5	3.26	2.37	0.7	31.7	3.49	2.26	0.75	36.3	3.7	2.16	0.8	40.7	3.88	2.05	0.83	44.8
	5	3.4	2.08	0.58	22.0	3.11	2.32	0.53	18.4	3.33	2.18	0.57	21.1	3.55	2.08	0.61	24.0	3.73	3.23	0.64	26.5
	6	3.25	2.03	0.47	13.9	2.96	2.24	0.42	11.6	3.18	2.11	0.46	13.4	3.41	2	0.49	15.3	3.57	1.9	0.51	16.8
	7	3.09	1.93	0.38	9.3	2.8	2.18	0.34	7.6	3.02	2.04	0.37	8.8	3.24	1.93	0.4	10.2	3.42	1.82	0.42	11.4
6	3	3.49	2.14	1	64.2	3.18	2.36	0.91	53.3	3.41	2.23	0.98	61.3	3.63	2.13	1.04	69.6	3.84	2.03	1.1	77.8
	4	3.35	2.06	0.72	33.3	3.03	2.28	0.65	27.4	3.27	2.16	0.7	31.8	3.49	2.06	0.75	36.1	3.68	1.96	0.79	40.3
	5	3.18	1.99	0.55	19.3	2.9	2.22	0.5	16.0	3.12	2.09	0.54	18.5	3.33	1.97	0.57	21.1	3.54	1.88	0.61	23.8
	6	3.03	1.93	0.43	12.2	2.75	2.14	0.39	10.0	2.96	2.01	0.42	11.6	3.18	1.9	0.46	13.4	3.36	1.8	0.48	14.9
	7	2.87	1.84	0.35	8.0	2.57	2.09	0.32	6.4	2.8	1.96	0.34	7.6	3	1.83	0.37	8.8	3.21	1.72	0.39	10.0
7	3	3.26	2.03	0.93	56.0	2.95	2.26	0.85	46.1	3.18	2.14	0.91	53.6	3.42	2.03	0.98	61.8	3.61	1.92	1.04	68.9
	4	3.12	1.96	0.67	29.0	2.8	2.21	0.6	23.3	3.04	2.07	0.65	27.4	3.26	1.96	0.7	31.7	3.47	1.86	0.75	35.8
	5	2.96	1.89	0.51	16.7	2.66	2.14	0.46	13.4	2.9	2	0.5	16.0	3.11	1.87	0.53	18.4	3.3	1.79	0.57	20.7
	6	2.81	1.84	0.4	10.4	2.5	2.08	0.36	8.3	2.76	1.92	0.4	10.1	2.97	1.8	0.43	11.6	3.15	1.71	0.45	13.1
	7	2.66	1.75	0.33	6.9	2.34	2	0.29	5.3	2.57	1.87	0.32	6.4	2.79	1.75	0.34	7.6	2.98	1.64	0.37	8.6
8	3	3.03	1.95	0.87	48.6	2.71	2.18	0.78	38.7	2.96	2.04	0.85	46.4	3.19	1.92	0.91	53.7	3.39	1.82	0.97	60.9
	4	2.9	1.88	0.62	25.0	2.57	2.11	0.55	19.7	2.81	1.99	0.6	23.5	3.03	1.86	0.65	27.4	3.23	1.77	0.69	31.0
	5	2.75	1.8	0.47	14.4	2.41	2.05	0.42	11.1	2.67	1.91	0.46	13.6	2.9	1.8	0.5	16.0	3.09	1.69	0.53	18.2
	6	2.57	1.75	0.37	8.8	2.26	2	0.32	6.8	2.52	1.84	0.36	8.4	2.75	1.72	0.39	10.0	2.94	1.62	0.42	11.4
	7	2.42	1.67	0.3	5.7	2.1	1.91	0.26	4.3	2.35	1.78	0.29	5.4	2.57	1.65	0.32	6.4	2.75	1.55	0.34	7.3
9	3	2.82	1.86	0.81	42.0	2.48	2.1	0.71	32.5	2.74	1.95	0.79	39.7	2.98	1.83	0.85	46.8	3.17	1.73	0.91	53.0
	4	2.66	1.79	0.57	21.1	2.34	2.04	0.5	16.2	2.58	1.89	0.56	19.8	2.8	1.78	0.6	23.4	3	1.67	0.65	26.8
	5	2.52	1.72	0.43	12.1	2.16	1.99	0.37	8.9	2.44	1.83	0.42	11.3	2.66	1.7	0.46	13.4	2.86	1.59	0.49	15.5
	6	2.35	1.65	0.34	7.3	2	1.93	0.29	5.3	2.27	1.77	0.33	6.8	2.51	1.62	0.36	8.3	2.71	1.52	0.39	9.7
	7	2.18	1.57	0.27	4.6	1.86	1.86	0.23	3.4	2.1	1.69	0.26	4.3	2.33	1.57	0.29	5.3	2.52	1.45	0.31	6.2
10	3	2.59	1.76	0.74	35.3	2.23	2.02	0.64	26.2	2.48	1.88	0.71	32.5	2.73	1.75	0.78	39.5	2.95	1.64	0.84	45.9
	4	2.43	1.69	0.52	17.5	2.06	1.98	0.44	12.6	2.34	1.82	0.5	16.3	2.58	1.69	0.56	19.8	2.77	1.58	0.6	22.9
	5	2.27	1.64	0.39	9.8	1.93	1.93	0.33	7.1	2.17	1.76	0.37	9.0	2.42	1.62	0.42	11.1	2.63	1.51	0.45	13.1
	6	2.11	1.57	0.3	5.9	1.83	1.83	0.26	4.4	2.02	1.69	0.29	5.4	2.26	1.53	0.32	6.8	2.46	1.43	0.35	8.0
	7	1.93	1.5	0.24	3.6	1.72	1.72	0.21	2.9	1.84	1.63	0.23	3.3	2.07	1.49	0.25	4.2	2.3	1.36	0.28	5.1
11	3	2.34	1.68	0.67	28.8	1.98	1.98	0.57	20.7	2.25	1.79	0.65	26.8	2.49	1.67	0.71	32.7	2.71	1.55	0.78	38.7
	4	2.19	1.62	0.47	14.2	1.88	1.88	0.4	10.5	2.1	1.72	0.45	13.1	2.34	1.59	0.5	16.3	2.56	1.49	0.55	19.4
	5	2.02	1.56	0.35	7.8	1.79	1.79	0.31	6.1	1.93	1.68	0.33	7.1	2.18	1.53	0.37	9.0	2.39	1.42	0.41	10.9
	6	1.84	1.5	0.26	4.5	1.68	1.68	0.24	3.7	1.77	1.61	0.25	4.1	2.01	1.48	0.29	5.3	2.22	1.35	0.32	6.5
	7	1.64	1.44	0.2	2.6	1.58	1.58	0.19	2.4	1.58	1.58	0.19	2.4	1.82	1.4	0.22	3.2	2.04	1.27	0.25	4.1
12	3	2.09	1.6	0.6	23.0	1.83	1.83	0.53	17.8	1.99	1.73	0.57	20.9	2.25	1.58	0.65	26.8	2.46	1.47	0.71	32.0
	4	1.93	1.55	0.42	11.1	1.75	1.75	0.38	9.1	1.84	1.67	0.39	10.0	2.09	1.52	0.45	13.0	2.31	1.4	0.5	15.9
	5	1.77	1.49	0.3	5.9	1.67	1.67	0.29	5.3	1.67	1.62	0.29	5.3	1.93	1.46	0.33	7.1	2.15	1.34	0.37	8.8
	6	1.57	1.44	0.22	3.3	1.55	1.55	0.22	3.2	1.55	1.52	0.22	3.2	1.75	1.4	0.25	4.0	1.97	1.26	0.28	5.1
	7	1.39	1.39	0.17	1.9	1.44	1.44	0.18	2.0	1.43	1.43	0.18	2.0	1.53	1.33	0.19	2.3	1.79	1.19	0.22	3.1
13	3	1.82	1.53	0.52	17.6	1.69	1.69	0.48	15.1	1.72	1.66	0.49	15.6	1.98	1.5	0.57	20.8	2.22	1.39	0.64	26.0
	4	1.67	1.47	0.36	8.3	1.61	1.61	0.35	7.7	1.61	1.58	0.35	7.7	1.82	1.46	0.39	9.9	2.06	1.32	0.44	12.6
	5	1.49	1.46	0.26	4.2	1.5	1.5	0.26	4.3	1.51	1.51	0.26	4.3	1.67	1.39	0.29	5.3	1.9	1.26	0.33	6.8
	6	1.36	1.36	0.19	2.4	1.4	1.4	0.2	2.6	1.4	1.4	0.2	2.6	1.47	1.34	0.21	2.9	1.71	1.19	0.25	3.9
	7	1.24	1.24	0.15	1.5	1.28	1.28	0.16	1.6	1.29	1.29	0.16	1.6	1.29	1.26	0.16	1.6	1.5	1.12	0.18	2.2

MKD-500S																						
EWT	Δt	Air inlet condition																				
		DB:26.7 WB:19.4				DB:27 WB:18				DB:27 WB:19				DB:27 WB:20				DB:29 WB:21				
		TC	SC	WF	WPD	TC	SC	WF	WPD	TC	SC	WF	WPD	TC	SC	WF	WPD	TC	SC	WF	WPD	
5	3	4.46	2.69	1.28	108.2	4.09	2.95	1.17	91.1	4.37	2.8	1.25	103.9	4.62	2.68	1.32	116.2	4.88	2.56	1.4	129.5	
	4	4.29	2.61	0.92	56.3	3.94	2.86	0.85	47.5	4.22	2.72	0.91	54.4	4.46	2.61	0.96	61.0	4.69	2.47	1.01	67.3	
	5	4.1	2.52	0.71	33.0	3.75	2.8	0.65	27.6	4.02	2.64	0.69	31.7	4.29	2.51	0.74	36.0	4.51	3.89	0.77	39.8	
	6	3.92	2.44	0.56	20.9	3.57	2.7	0.51	17.4	3.84	2.55	0.55	20.1	4.11	2.41	0.59	23.0	4.31	2.29	0.62	25.3	
	7	3.73	2.33	0.46	13.9	3.37	2.64	0.41	11.4	3.64	2.46	0.45	13.3	3.91	2.33	0.48	15.3	4.13	2.2	0.51	17.0	
6	3	4.21	2.58	1.21	96.3	3.83	2.84	1.1	80.0	4.11	2.69	1.18	92.0	4.38	2.57	1.26	104.4	4.63	2.44	1.33	116.7	
	4	4.04	2.49	0.87	50.0	3.66	2.75	0.79	41.0	3.94	2.6	0.85	47.6	4.21	2.48	0.9	54.2	4.44	2.36	0.96	60.5	
	5	3.84	2.4	0.66	28.9	3.49	2.68	0.6	23.9	3.77	2.53	0.65	27.8	4.02	2.38	0.69	31.6	4.27	2.27	0.73	35.7	
	6	3.66	2.33	0.52	18.2	3.31	2.59	0.47	14.9	3.58	2.43	0.51	17.4	3.84	2.29	0.55	20.1	4.06	2.17	0.58	22.4	
	7	3.47	2.22	0.43	12.0	3.11	2.52	0.38	9.6	3.38	2.36	0.42	11.5	3.63	2.21	0.45	13.1	3.87	2.08	0.48	15.0	
7	3	3.93	2.45	1.13	84.0	3.57	2.73	1.02	69.2	3.84	2.58	1.1	80.4	4.13	2.45	1.18	92.7	4.36	2.32	1.25	103.4	
	4	3.77	2.37	0.81	43.5	3.38	2.67	0.73	35.0	3.67	2.49	0.79	41.2	3.94	2.37	0.85	47.5	4.19	2.25	0.9	53.7	
	5	3.58	2.28	0.62	25.1	3.21	2.59	0.55	20.2	3.5	2.41	0.6	24.0	3.75	2.26	0.65	27.6	3.98	2.16	0.69	31.1	
	6	3.39	2.22	0.49	15.6	3.02	2.51	0.43	12.4	3.33	2.32	0.48	15.1	3.58	2.18	0.51	17.5	3.8	2.06	0.55	19.7	
	7	3.21	2.12	0.39	10.3	2.82	2.41	0.35	7.9	3.1	2.25	0.38	9.6	3.37	2.11	0.41	11.3	3.6	1.97	0.44	13.0	
8	3	3.66	2.35	1.05	73.0	3.27	2.64	0.94	58.1	3.58	2.46	1.03	69.6	3.85	2.32	1.1	80.6	4.1	2.2	1.17	91.3	
	4	3.5	2.27	0.75	37.5	3.11	2.55	0.67	29.5	3.39	2.4	0.73	35.3	3.66	2.25	0.79	41.0	3.9	2.13	0.84	46.5	
	5	3.32	2.17	0.57	21.6	2.91	2.47	0.5	16.6	3.22	2.3	0.55	20.3	3.49	2.17	0.6	23.9	3.73	2.05	0.64	27.3	
	6	3.11	2.11	0.45	13.1	2.73	2.41	0.39	10.1	3.05	2.22	0.44	12.6	3.31	2.07	0.47	14.9	3.55	1.95	0.51	17.1	
	7	2.92	2.01	0.36	8.6	2.53	2.31	0.31	6.4	2.83	2.15	0.35	8.0	3.1	1.99	0.38	9.6	3.32	1.87	0.41	11.0	
9	3	3.4	2.24	0.98	63.1	2.99	2.54	0.86	48.8	3.31	2.35	0.95	59.6	3.59	2.21	1.03	70.2	3.82	2.09	1.1	79.6	
	4	3.21	2.16	0.69	31.6	2.82	2.46	0.61	24.3	3.12	2.28	0.67	29.7	3.38	2.15	0.73	35.1	3.63	2.02	0.78	40.3	
	5	3.04	2.07	0.52	18.1	2.61	2.4	0.45	13.3	2.94	2.21	0.51	17.0	3.21	2.06	0.55	20.2	3.45	1.92	0.59	23.3	
	6	2.84	1.99	0.41	11.0	2.41	2.33	0.35	7.9	2.74	2.14	0.39	10.2	3.03	1.96	0.43	12.5	3.27	1.83	0.47	14.5	
	7	2.63	1.9	0.32	6.9	2.25	2.25	0.28	5.1	2.54	2.04	0.31	6.4	2.81	1.9	0.34	7.9	3.04	1.75	0.37	9.2	
10	3	3.12	2.13	0.89	53.0	2.69	2.44	0.77	39.3	2.99	2.27	0.86	48.8	3.3	2.12	0.95	59.2	3.56	1.98	1.02	68.8	
	4	2.93	2.05	0.63	26.3	2.48	2.39	0.53	18.9	2.83	2.19	0.61	24.5	3.12	2.04	0.67	29.7	3.35	1.9	0.72	34.3	
	5	2.74	1.98	0.47	14.7	2.33	2.33	0.4	10.6	2.62	2.12	0.45	13.5	2.92	1.95	0.5	16.7	3.17	1.82	0.55	19.7	
	6	2.55	1.89	0.37	8.9	2.21	2.21	0.32	6.6	2.43	2.04	0.35	8.1	2.73	1.85	0.39	10.1	2.96	1.73	0.42	12.0	
	7	2.33	1.81	0.29	5.4	2.08	2.08	0.26	4.3	2.22	1.96	0.27	4.9	2.5	1.79	0.31	6.3	2.77	1.64	0.34	7.7	
11	3	2.82	2.03	0.81	43.2	2.39	2.39	0.68	31.1	2.72	2.16	0.78	40.2	3	2.02	0.86	49.0	3.27	1.87	0.94	58.1	
	4	2.64	1.96	0.57	21.4	2.27	2.27	0.49	15.8	2.54	2.08	0.55	19.7	2.82	1.92	0.61	24.4	3.09	1.8	0.66	29.2	
	5	2.44	1.88	0.42	11.7	2.16	2.16	0.37	9.2	2.33	2.03	0.4	10.6	2.63	1.84	0.45	13.5	2.88	1.71	0.5	16.3	
	6	2.22	1.81	0.32	6.7	2.03	2.03	0.29	5.6	2.14	1.94	0.31	6.2	2.42	1.78	0.35	8.0	2.68	1.63	0.38	9.8	
	7	1.98	1.74	0.24	3.9	1.91	1.91	0.23	3.6	1.91	1.91	0.23	3.6	2.2	1.69	0.27	4.8	2.46	1.53	0.3	6.1	
12	3	2.52	1.93	0.72	34.6	2.21	2.21	0.63	26.6	2.4	2.09	0.69	31.3	2.72	1.9	0.78	40.2	2.97	1.77	0.85	48.0	
	4	2.33	1.87	0.5	16.7	2.11	2.11	0.45	13.6	2.22	2.02	0.48	15.1	2.53	1.83	0.54	19.5	2.79	1.69	0.6	23.9	
	5	2.13	1.8	0.37	8.9	2.02	2.02	0.35	8.0	2.02	1.95	0.35	8.0	2.33	1.77	0.4	10.6	2.59	1.62	0.45	13.2	
	6	1.89	1.74	0.27	4.9	1.87	1.87	0.27	4.8	1.87	1.84	0.27	4.8	2.11	1.69	0.3	6.1	2.37	1.53	0.34	7.7	
	7	1.68	1.68	0.21	2.8	1.74	1.74	0.21	3.0	1.73	1.73	0.21	3.0	1.84	1.61	0.23	3.4	2.16	1.43	0.26	4.7	
13	3	2.2	1.85	0.63	26.4	2.04	2.04	0.58	22.7	2.08	2.01	0.6	23.5	2.39	1.81	0.69	31.2	2.68	1.67	0.77	39.0	
	4	2.02	1.78	0.43	12.4	1.94	1.94	0.42	11.6	1.94	1.91	0.42	11.6	2.2	1.77	0.47	14.8	2.48	1.59	0.53	18.9	
	5	1.8	1.76	0.31	6.3	1.81	1.81	0.31	6.4	1.82	1.82	0.31	6.5	2.01	1.68	0.35	7.9	2.29	1.52	0.39	10.3	
	6	1.64	1.64	0.23	3.6	1.69	1.69	0.24	3.9	1.69	1.69	0.24	3.9	1.77	1.62	0.25	4.3	2.07	1.43	0.3	5.8	
	7	1.49	1.49	0.18	2.2	1.55	1.55	0.19	2.4	1.56	1.56	0.19	2.4	1.56	1.52	0.19	2.4	1.81	1.35	0.22	3.3	

Cooling capacity modification coefficient table:

Speed	300		400		500	
	TC	SC	TC	SC	TC	SC
High	1	1	1	1	1	1
Mid	0.9	0.87	0.84	0.78	0.79	0.78
Low	0.78	0.72	0.69	0.62	0.69	0.66

Heating Capacity:

Remark:

Δt : Temperature Difference (°C); **TH**: Total Heating Capacity (kW); **WF**: Water Flow (m³/h); **WPD**: Water Pressure Drop (kPa)

MKD-300S																									
Δt		Air inlet temp. (20°C DB)																							
		Water inlet temp. (°C)																							
		35			40			45			50			55			60			65			70		
		TH	WF	WPD	TH	WF	WPD	TH	WF	WPD	TH	WF	WPD	TH	WF	WPD	TH	WF	WPD	TH	WF	WPD	TH	WF	WPD
10	0.74	0.06	0.7	1.16	0.10	1.7	1.60	0.14	3.2	2.02	0.17	5.1	2.44	0.21	7.4	2.87	0.25	10.2	3.29	0.28	13.4	3.70	0.32	17.0	
8	0.82	0.09	1.3	1.27	0.14	3.1	1.71	0.18	5.6	2.13	0.23	8.8	2.54	0.27	12.5	2.95	0.32	16.9	3.36	0.36	22.0	3.78	0.41	27.7	
6	0.95	0.14	3.1	1.38	0.20	6.6	1.79	0.26	11.0	2.22	0.32	17.0	2.64	0.38	24.0	3.05	0.44	32.2	3.44	0.49	40.8	3.88	0.56	52.0	
MKD-400S																									
Δt		Air inlet temp. (20°C DB)																							
		Water inlet temp. (°C)																							
		35			40			45			50			55			60			65			70		
		TH	WF	WPD	TH	WF	WPD	TH	WF	WPD	TH	WF	WPD	TH	WF	WPD	TH	WF	WPD	TH	WF	WPD	TH	WF	WPD
10	0.92	0.08	0.9	1.44	0.12	2.2	1.99	0.17	4.3	2.51	0.22	6.9	3.04	0.26	10.0	3.57	0.31	13.9	4.09	0.35	18.1	4.60	0.40	23.0	
8	1.02	0.11	1.8	1.58	0.17	4.3	2.12	0.23	7.6	2.64	0.28	11.9	3.15	0.34	16.9	3.67	0.39	22.8	4.18	0.45	29.7	4.70	0.50	37.5	
6	1.18	0.17	4.2	1.71	0.25	8.9	2.22	0.32	14.9	2.76	0.40	23.0	3.28	0.47	32.5	3.80	0.54	43.5	4.28	0.61	55.3	4.83	0.69	70.3	
MKD-500S																									
Δt		Air inlet temp. (20°C DB)																							
		Water inlet temp. (°C)																							
		35			40			45			50			55			60			65			70		
		TH	WF	WPD	TH	WF	WPD	TH	WF	WPD	TH	WF	WPD	TH	WF	WPD	TH	WF	WPD	TH	WF	WPD	TH	WF	WPD
10	1.02	0.09	1.1	1.59	0.14	2.6	2.21	0.19	5.1	2.79	0.24	8.1	3.37	0.29	11.8	3.96	0.34	16.3	4.53	0.39	21.3	5.10	0.44	27.0	
8	1.13	0.12	2.1	1.75	0.19	5.0	2.35	0.25	9.0	2.93	0.32	13.9	3.50	0.38	19.8	4.07	0.44	26.8	4.64	0.50	34.9	5.21	0.56	44.0	
6	1.31	0.19	4.9	1.90	0.27	10.4	2.46	0.35	17.5	3.06	0.44	27.0	3.64	0.52	38.2	4.21	0.60	51.1	4.74	0.68	64.9	5.35	0.77	82.5	

Heating capacity modification coefficient table:

Speed	300	400	500
	TH	TH	TH
High	1	1	1
Mid	0.89	0.84	0.79
Low	0.79	0.74	0.67

Altitude modification coefficient table:

Altitude (m)	TC	SC	TH
500	0.98	0.95	0.95
1000	0.97	0.91	0.91
1500	0.95	0.86	0.86
2000	0.94	0.82	0.82
2500	0.93	0.78	0.78
3000	0.91	0.74	0.7

11. Exploded View

MKD-300S MKD-400S MKD-500S

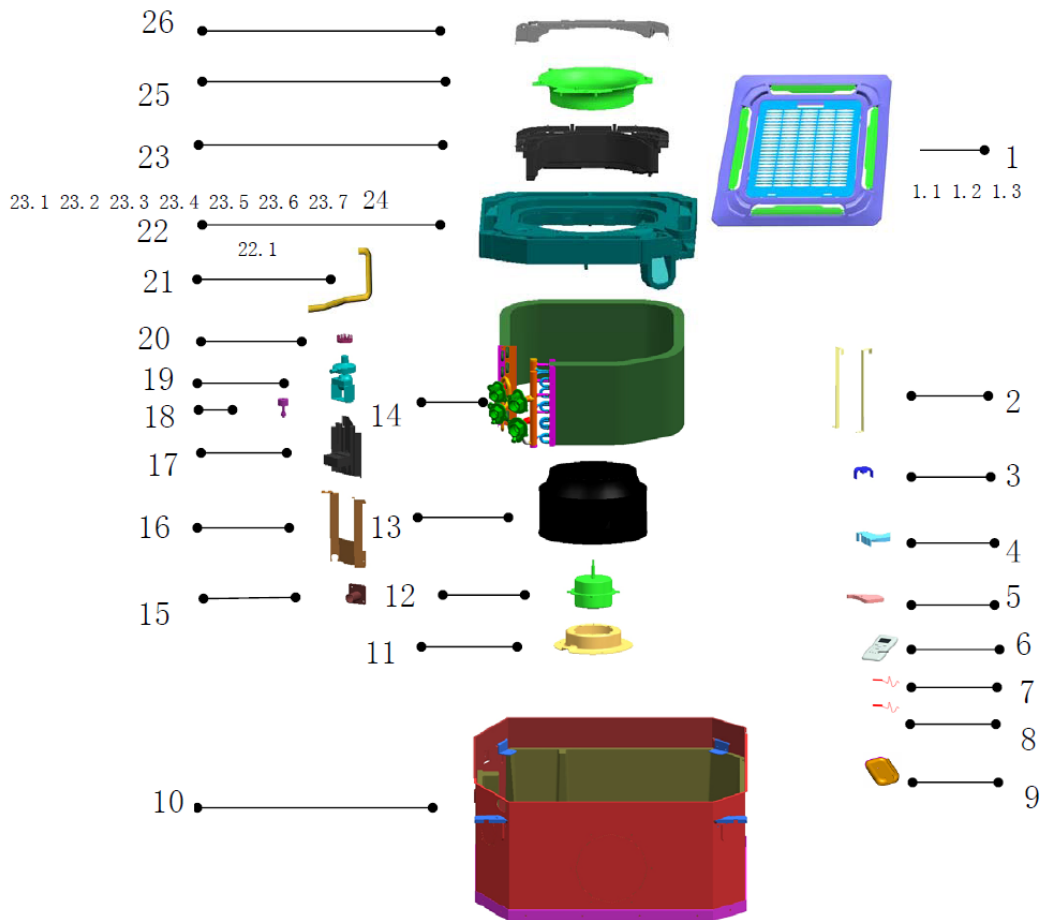

No.	Part Name	Quantity	No.	Part Name	Quantity
1	Panel	1	17	Drain pump installation base	1
1.1	Display board	1	18	Water level sensor ass'y	1
1.2	Swing motor	1	19	Drain pump	1
1.3	Room temp. sensor ass'y	1	20	Guard against block up net	1
2	Evaporator hang board	2	21	Drain pipe	1
3	Wire clamp	1	22	Drainage pan ass'y	1
4	Wire box	1	22.1	Plug	1
5	Cover box	1	23	E-part box ass'y	1
6	Remote controller	1	23.1	E-part box	1
7	Temp. sensor ass'y	1	23.2	Wire joint installation base	1
8	Temp. sensor ass'y	1	23.3	Fixture clip	3
9	Remote controller holder ass'y	1	23.4	Main control board ass'y	1
10	Base ass'y	1	23.5	Transformer	1
11	Motor installation base	1	23.6	Wire joint	1
12	Motor	1	23.7	Wire joint, 5p	1
13	Centrifugal fan	1	24	Motor capacitor	1
14	Evaporator ass'y	1	25	Ring	1
15	Connecting pipe	1	26	E-Part box cover	1
16	Evaporator fixing board	1			

12. Installation

12.1 Installation space

The indoor unit should be installed in a location that meets the following requirements:

- There is enough room for installation and maintenance.
- The ceiling is horizontal, and its structure can endure the weight of the indoor unit.
- The outlet and the inlet are not impeded, and the influence of external air is the least.
- The air flow can reach throughout the room.
- The connecting water pipe and drainpipe could be extracted out easily.
- There is no direct radiation from heaters.

Caution:

Keep indoor unit, outdoor unit, power supply wiring and transmission wiring at least 1 meter away from televisions and radios. This is to prevent image interference and noise in those electrical appliances. (Noise may be generated depending on the conditions under which the electric wave is generated, even if 1 meter is kept.)

12.2 Install the main body

A. The existing ceiling (to be horizontal)

- a. Cut a quadrangular hole of 880×880mm in the ceiling according to the shape of the installation paper board.
 - The center of the hole should be at the same position of that of the air conditioner body.
 - Determine the lengths and outlets of the connecting pipe, drain pipe and cables.
 - To balance the ceiling and to avoid vibration, please enforce the ceiling when necessary.
- b. Select the position of installation hooks according to the hook holes on the installation board.
 - Drill four holes of $\varnothing 12\text{mm}$, 50~55mm deep at the selected positions on the ceiling. Then embed the expansible hooks (fittings).
 - Face the concave side of the installation hooks toward the expansible hooks. Determine the length of the installation hooks from the height of ceiling, and then cut off the unnecessary part.
 - If the ceiling is extremely high, please determine the length of the installation hook according to facts.
- c. Adjust the hexangular nuts on the four installation hooks evenly, to ensure the balance of the body.
 - If the drainpipe is awry, leakage will be caused by the malfunction of the water-level switch.
 - Adjust the position to ensure the gaps between the body and the four sides of ceiling are even. The body's lower part should sink into the ceiling for 10~12 mm.

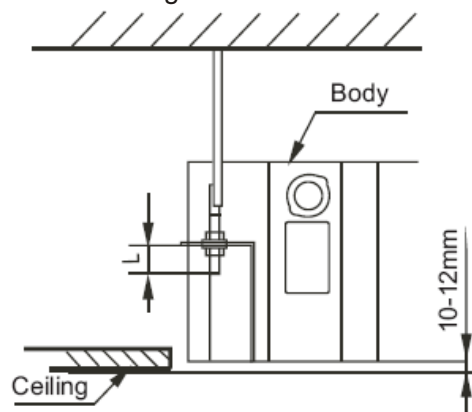

- In general, L is half of the screw length of the installation hook.
- Locate the air conditioner firmly by wrenching the nuts after having adjusted the body's position well.

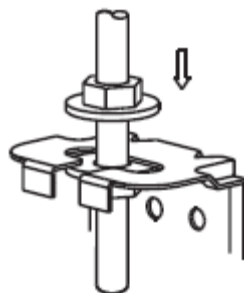

B. New built houses and ceilings

- a. In the case of new built house, the hook can be embedded in advance (refer to the A.b mentioned above). But it should be strong enough to bear the indoor unit and will not become loose because of concrete shrinking.
- b. After installing the body, please fasten the installation paper board onto the air conditioner with bolts (M6*12) to determine in advance the sizes and positions of the hole opening on ceiling.

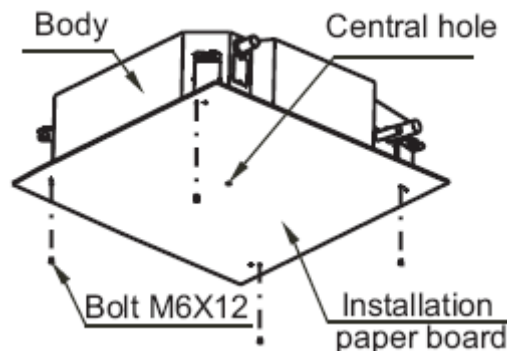

- Please first guarantee the flatness and horizontal of ceiling when installing it.
 - Refer to the A.a mentioned above for others.
- c. Refer to the A.c mentioned above for installation.
 - d. Remove the installation paper board.

Caution:

After installing the body, the four bolts(M6x12) must be fastened to the air conditioner onto ensure the body is grounded well.

12.3 Install the Panel**Caution:**

Never put the panel face down on floor or against the wall, or on bulgy objects.

Never crash or strike it.

(1) Remove the air inlet grill.

- a. Slide two grid switches toward the middle at the same time, and then pull them up.

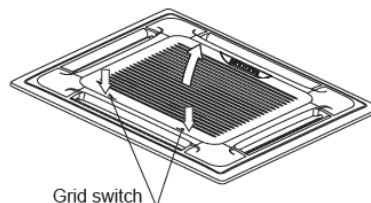

- b. Draw the grid up to an angle of about 45°, and remove it.

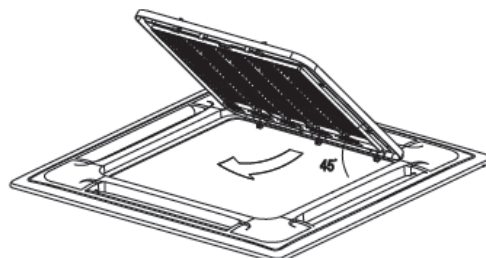
**(2) Remove the installation covers at the four corners.**

Wrench off the bolts, loose the rope of the installation covers, and remove them.

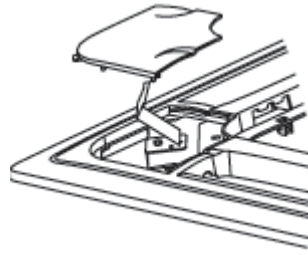

(3) Install the panel

- a. Align the swing motor on the panel to the tubing joints of the body properly.
- b. Fix hooks of the panel at swing motor and its opposite sides to the hooks of corresponding water receiver. Then hang the other two panel hooks onto corresponding hangers of the body.

Cautions

Do not coil the wiring of the swing motor into the seal sponge.

- c. Adjust the four panel hook screws to keep the panel horizontal, and screw them up to the ceiling evenly.
- d. Regulate the panel in the direction of the arrow slightly to fit the panel's center to the center of the ceiling's opening. Guarantee that hooks of four corners are fixed well.
- e. Keep fastening the screws under the panel hooks, until the thickness of the sponge between the body and the panel's outlet has been reduced to about 4~6mm. The edge of the panel should contact with the ceiling well.

If the gap between the panel and ceiling still exists after fastening the screws, the height of the indoor unit should be modified again.

You can modify the height of the indoor unit through the openings on the panel's four corners; if the lift of the indoor unit and the drainpipe is not influenced.

(4) Hang the air-in grid to the panel, and then connect the lead terminator of the swing motor and that of the control box with corresponding terminators on the body respectively.

(5) Relocate the air-in grid in the procedure of reversed order.

(6) Relocate the installation cover.

- a. Fasten the rope of installation cover on the bolt of the installation cover. (Refer to chart 16-left)
- b. Press the installation cover into the panel slightly. (Refer to chart 16-right)

12.4 Connect the Drain Pipe

12.4.1 Install the drainpipe

- You can use a polyethylene tube as the drainpipe (out-dia. 37~39mm, in-dia. 32mm). It could be bought at local market or from your dealer.
- Set the mouth of the drainpipe onto the root of the body's pump-pipe, and clip the drainpipe and the out-let pipe sheath (fittings) together firmly with the out-let pipe clasp (fitting).

Cautions:

Use your strength carefully to prevent the pump-pipe from breaking.

- The body's pump pipe and the drainpipe (especially the indoor part) should be covered evenly with the out-let pipe sheath (fittings) and be bound tightly with the constrictor to prevent condensation caused by entered air.
- To prevent water from flowing backwards into the air conditioner while the air conditioner stops, please lean the drainpipe down toward outdoor (outlet-side) at a degree of over 1/50. And please avoid any bulge or water deposit. (Refer to the following)

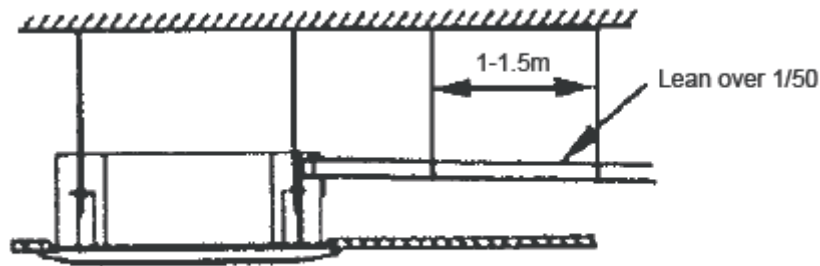

- Do not drag the drainpipe violently when connecting to prevent the body from being pulled.
- Meanwhile, one support-point should be set every 1~1.5m to prevent the drainpipe from yielding. Or you can tie the drainpipe with the connecting pipe to fix it.

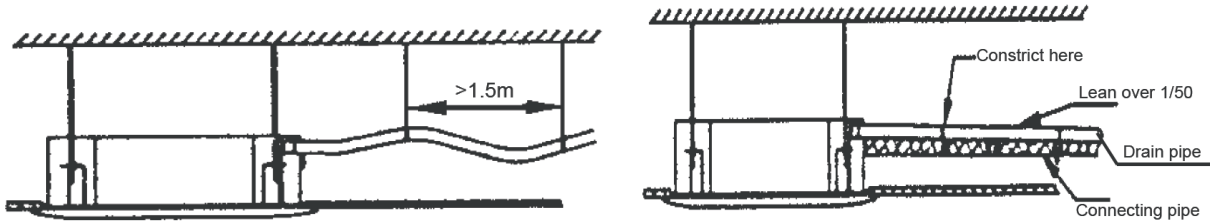

- In the case of prolonged drainpipe, you had better tighten its indoor part with a protection tube to prevent it from losing.
- If the outlet of the drainpipe is higher than the body's pump joint, the pipe should be arranged as vertically as possible. And the lift distance must be less than 500mm, otherwise the water will overflow when the air conditioner stops.
- The end of the drainpipe should be over 50mm higher than the ground or the bottom of the drainage chute, and do not immerse it in water. If you discharge the water directly into sewage is sure to make a U-form aqua seal by bending the pipe up to prevent the smelly gas entering the house through the drain pipe.

Cautions:

All the joints of the drain system must be sealed to prevent water leakage.

1. All field piping must be provided by a licensed water technician and must comply with the relevant local and national codes.
2. Do not let air, dust, or other impurities fall in the pipe system during the time of installation.
3. The connecting pipe should not be installed until the indoor and outdoor units have been fixed already.
4. Keep the connecting pipe dry, and do not let moisture in during installation.

Note:

All the pictures in this manual are for explanation purpose only. They may be slightly different from the air conditioner you purchased (depend on model).The actual shape shall prevail.

12.4.2 Drainage test

- Check whether the drainpipe is unhindered.
 - New built house should have this test done before paving the ceiling.
1. Remove the test cover, and stow water of about 2000ml to the water receiver through the stow tube.

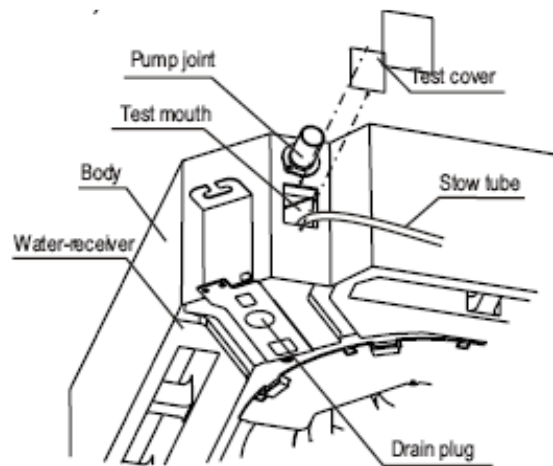

2. Turn on the power, and operate the air conditioner under the "COOLING" mode. Listen to the sound of the drain pump. Check whether the water is discharged well (a lag of 1min is allowed before discharging, according to the length of the drain pipe), and check whether water leaks from the joints.

Caution: If there is any malfunction, please resolve it immediately.

3. Stop the air conditioner for three minutes, check if everything is ok. If the drain hose is located unreasonable, water overflow will cause the Alarm indicator lamp flashing (For both cooling and heating type or cooling only type), even the water leak out from the water receiver.
 4. Check the drain pump whether drain water immediately when alarm sound for the high water lever. If the water lever can't come down below to the limited water lever, the air conditioner will stop. Restart it until turn off the power and drain off all the water.
 5. Turn off the power, drain the water away.
- The drain plug is used to empty the water-receiver for maintenance of the air conditioner. Please stuff it in position at all times during operation to avoid leakage.

12.5 Wiring

Caution:

1. The air conditioner should use separate power supply with rated voltage.
2. The external power supply to the air conditioner should have ground wiring, which is linked to the ground wiring of the indoor and outdoor unit.
3. The wiring work should be done by qualified persons according to circuit drawing.
4. An all-pole disconnection switch having a contact separation of at least 3mm in a pole should be connected in fixed wiring.
5. Be sure to locate the power wiring and the signal wiring well to avoid cross-disturbance.
6. Do not turn on the power until you have checked carefully after wiring.

Note:

Remark per EMC Directive 89/336/EEC to prevent flicker impressions during the start of the compressor (technical process), following installation conditions do apply.

1. The power connection for the air conditioner has to be done at the main power distribution. The distribution has to be of a low impedance, normally the required impedance reaches at a 32A fusing point.
2. No other equipment has to be connected with this power line.
3. For detailed installation acceptance please refer to your power supplier, if restrictions do apply for products like washing machines, air conditioners or electrical ovens.

4. For power details of the air conditioner refer to the rating plate of the product.
5. For any question contact your local dealer.

12.5.1 Connect the cable

- Disassemble the bolts from the cover.(If there isn't a cover on the outdoor unit, disassemble the bolts from the maintenance board, and pull it in the direction of the arrow to remove the protection board.)
- Connect the connective cables to the terminals as identified with their respective matched numbers on the terminal block of indoor and outdoor units.

Re-install the cover or the protection board.

12.5.2 Wiring figure

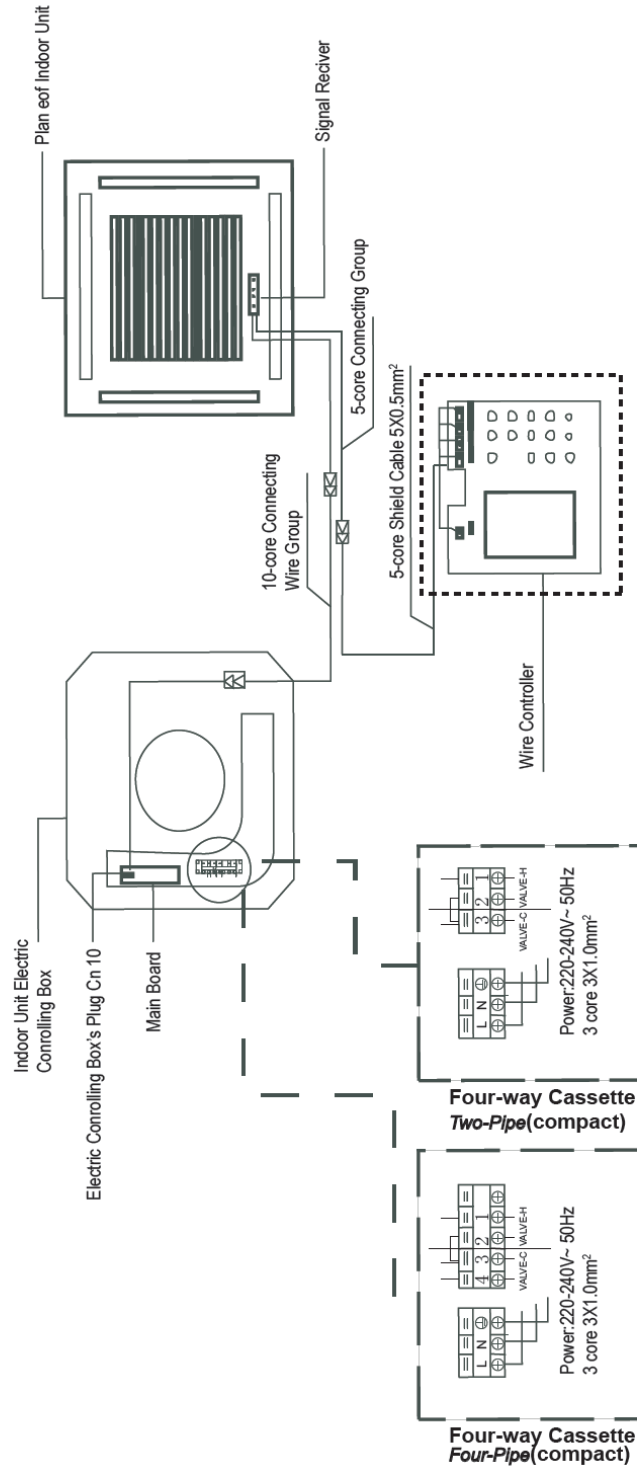

AIR CONDITIONER AND WIRE CONTROLLER WIRING

12.6 Troubleshooting

12.6.1 Troubles and causes of air conditioner

Symptoms	Causes	Solution
Unit does not start	<ul style="list-style-type: none"> Power failure. Power switch is off. Fuse of power switch may have burned. Batteries of remote controller exhausted or other problem of controller. 	<ul style="list-style-type: none"> Wait for the comeback of power. Switch on the power. Replace the fuse. Replace the batteries or check the controller.
Air flowing normally but completely can't cooling	<ul style="list-style-type: none"> Temperature is not setted correctly. 	<ul style="list-style-type: none"> Set the temperature properly.
Units start or stop frequently	<ul style="list-style-type: none"> Air or no concreting gas in the watering circuit. three-way valve is malfunction. Voltage is too high or too low. System circuit is blocked. Temperature is not setted correctly. 	<ul style="list-style-type: none"> Vacuum . Maintenance or change three-way valve. Install manostat. Find reasons and solution.
Low cooling effect	<ul style="list-style-type: none"> Indoor unit heat exchanger is dirty. The air filter is dirty. Inlet/outlet of indoor units is blocked. Doors and windows are open Sunlight directly shine. Too much heat resource. Leakage of water . 	<ul style="list-style-type: none"> Clean the heat exchanger. Clean the air filter. Eliminate all dirties and make air smooth. Close doors and windows. Make curtains in order to shelter from sunshine. Reduce heat source. AC cooling capacity reduces (normal). Check leakage .
Low heating effect	<ul style="list-style-type: none"> Doors and windows not completely closed. Leakage of water. 	<ul style="list-style-type: none"> Use heating device. Close doors and windows. Check leakage.

12.6.2 Troubles and causes of remote controller

Symptoms	Causes	Solution
The fan speed can not be changed.	<ul style="list-style-type: none"> ● Check whether the MODE indicated on the display is "AUTO" 	When the automatic mode is selected, the air conditioner will automatically change the fan speed.
	<ul style="list-style-type: none"> ● Check whether the MODE indicated on the display is "DRY" 	When dry operation is selected, the air conditioner automatically change the fan speed. The fan speed can be selected during "COOL", "FAN ONLY", and "HEAT"
The remote controller signal is not transmitted even when the ON/OFF button is pushed.	<ul style="list-style-type: none"> ● Check whether the batteries in the remote controller are exhausted. 	The power supply is off.
The TEMP. indicator does not come on.	<ul style="list-style-type: none"> ● Check whether the MODE indicated on the display is FAN ONLY 	The temperature cannot be set during FAN mode.
The indication on the display disappears after a lapse of time.	<ul style="list-style-type: none"> ● Check whether the timer operation has come to an end when the TIMER OFF is indicated on the display. 	The air conditioner operation will stop up to the set time
The TIMER ON indicator goes off after a lapse of certain time.	<ul style="list-style-type: none"> ● Check whether the timer operation is started when the TIMER ON is indicated on the display. 	Up to the set time, the air conditioner will automatically start and the appropriate indicator will go off.
No receiving tone sounds from the indoor unit even when the ON/OFF button is pressed.	<ul style="list-style-type: none"> ● Check whether the signal transmitter of the remote controller is properly directed to the infrared signal receiver of the indoor unit when the ON/OFF button is pressed. 	Directly transmit the signal transmitter of the remote controller to the infrared signal receiver of the indoor unit, and then repeatedly push the ON/OFF button twice.

12.6.3 Malfunctions and malfunction code

If anything happens like the situation described below, please shut off the power supply of the unit and contact with the customer service center immediately.

NO.	Malfunction	running lamp	timer lamp	defrosting lamp	alarm lamp
1	Room temperature sensor checking channel is abnormal.	X	☆	X	X
2	Evaporator sensor checking channel is abnormal.(T2C)	☆	X	X	X
3	Evaporator sensor checking channel is abnormal.(T2H)	☆	X	X	X
4	EEprom malfunction.	☆	☆	X	X
5	Fan failure	☆	☆	☆	X
6	Protection against freezing	☆	X	X	☆
7	Excess water temperature protection	☆	X	☆	X
8	Water-level switch malfunction.	X	X	X	☆
9	Not set models.	☆	☆	☆	☆
10	Indoor unit switch at long-range controller is dialed to OFF.	----	----	----	----

(× Extinguish, ☆ Flash at 5Hz)

12.7 Test operation

(1) The test operation must be carried out after the entire installation has been completed.

(2) Please confirm the following points before the test operation.

The indoor unit and outdoor unit are installed properly.

Tubing and wiring are correctly completed.

The refrigerant pipe system is leakage-checked.

The drainage is unimpeded.

The ground wiring is connected correctly.

The length of the tubing and the added stow capacity of the refrigerant have been recorded.

The power voltage fits the rated voltage of the air conditioner.

There is no obstacle at the outlet and inlet of the outdoor and indoor units.

The gas-side and liquid-side stop valves are both opened.

The air conditioner is pre-heated by turning on the power.

(3) According to the user's requirement, install the remote controller when the remote controller's signal can reach the indoor unit smoothly.

(4) Test operation

Set the air conditioner under the mode of "COOLING" with the remote controller, and check the following points.

- Whether the switch on the remote controller works well.
- Whether the buttons on the remote controller works well.
- Whether the air flow louver moves normally.
- Whether the room temperature is adjusted well.
- Whether the indicator lights normally.
- Whether the temporary buttons works well.
- Whether the drainage is normal.
- Whether there is vibration or abnormal noise during operation.
- Whether the air conditioner heats well in the case of the HEATING/COOLING type.